

Larson Manufacturing

Storm Door Warranty Claim Form



We regret that you are having difficulty with your Larson Storm Door, and you can be assured that we will address your concerns as quickly as possible. At Larson Manufacturing, we strive for customer satisfaction, and we take pride in offering the best warranty in the industry.

For warranty claims on the core or door rim, have customer complete the form and mail it to the address below.

If the customer needs parts (including warranty parts) or help troubleshooting a problem with the door, and does not know the model number, have them complete the Door Identification Questionnaire located in the Parts and Accessories Section. Then call the Larson Helpline: **1-888-483-3768** or visit **www.larsondoors.com**.

To avoid unnecessary delays, please provide the following information:

- 1. Copy of the Proof of Purchase**
- 2. Pictures of the door showing the following:**
 - a. Front view showing the entire door
 - b. The damaged or defective area
 - c. The Larson Logo Corner Caps on the inside face of the door in the upper right hand corner of the window opening (refer to illustration)

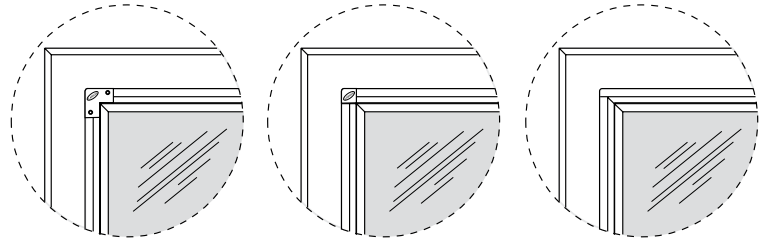

INSIDE VIEW OF DOOR (TOP LEFT -HAND CORNER)

- 3. Answer all the questions on the back side of this letter.**

4. Daytime phone number: _____

5. E-mail address: (if available) _____

6. Please provide shipping address:

NAME _____

STREET _____

CITY _____ STATE _____ ZIP _____

7. If your mailing address is different than above, please indicate below.

STREET _____

CITY _____ STATE _____ ZIP _____

Once you have completed this form, send the form along with the pictures of the door and a copy of your sales receipt to:

LARSON MANUFACTURING
ATTN: WARRANTY CLAIMS DEPT.
2333 EASTBROOK DRIVE
BROOKINGS, SD 57006

Once we review this information, we will then contact you in regards to the status of your claim. The information provided will help us determine your warranty needs. Again, we regret any difficulty you are having with your Larson Storm Door. We appreciate your business and will work to resolve this matter as timely as possible.

If your door has been damaged by an act of nature, or has been modified, altered or shortened in any way, the warranty is void. Do not dispose of the door or its components until your warranty claim is settled. Warranty applies to the original owner only and Proof of Purchase is required. Reinstallation cost is not covered under the warranty. Shipping charges may apply.

For faster service ensure all answers are completed

1. What color is your door? _____

2. What color is the inside handle? _____

3. How thick does the door measure? _____

OVERLAP FRAMES
 1-3/8" thick
 1-5/8" thick
 1-7/8" thick

CLASSIC-VIEW
 1-1/4" thick
 1-1/2" thick

WOOD-CORE
 1" thick

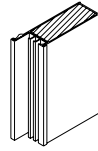
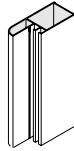
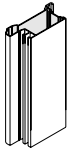

Door finish: smooth metal finish
 rough vinyl texture

4. Measure the width and height of the **door only**.
 Do **NOT** include the side z-bars or expander in the measurement.

DEFINITIONS:

Z-bar is the frame attached to the house

Expander fits over the bottom of the door and includes black rubber sweep

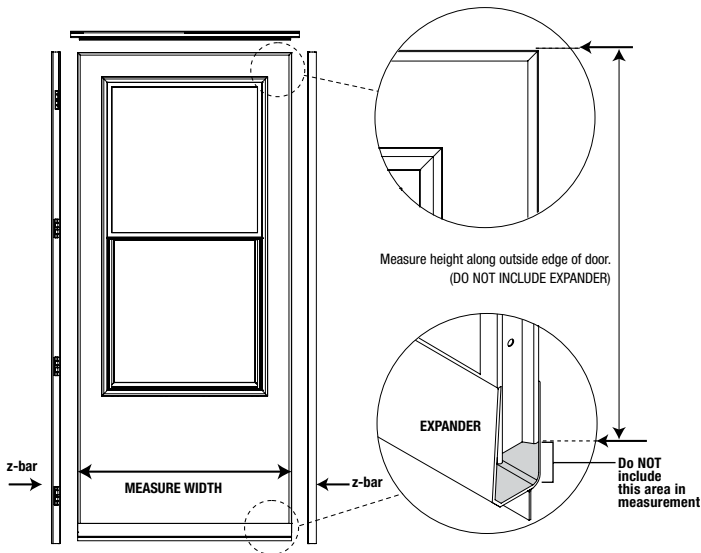

WIDTH: _____ HEIGHT: _____

5. Is the expander on the bottom of the door made of (check one):
 metal
 vinyl (plastic)

6. What type of weatherstripping does the z-bar have (check one)?

Felt
 Rubber

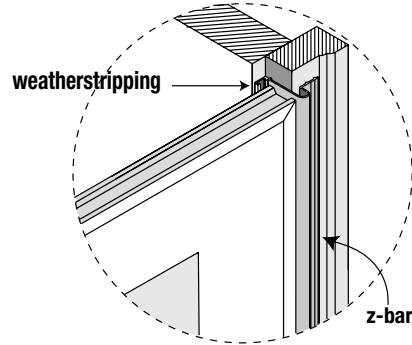

7. Remove either the screen or the glass insert and measure tip to tip:

WIDTH: _____ HEIGHT: _____

Does the screen insert take up the entire window opening or just half? _____

8. What is the door's Registration Number?

Possible Registration Number locations

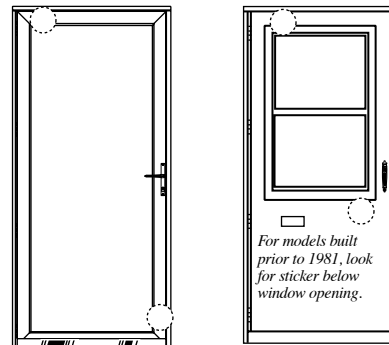

The number is in different locations depending on the model/date of your door.

For doors manufactured before 1997, the registration number is a 9 digit number stamped into the inside face of the door.

For doors manufactured after 1997, look for the sticker (similar to one below), either on the hinge side z-bar or the edge of the door.

Example: Larson Manufacturing
REG#: 028832U.111970506

NOTE: formats may vary